

Series 40 - Suspended Solids Sensors

Immersion Sensors

Immersion style sensors are designed for continuous on-line monitoring of suspended solids in industrial/municipal water and waste water treatment plants.

Applications:

- Effluent monitoring in clarifier overflow weirs
- Raw water inlet turbidity measurements in water treatment plants
- Final effluent monitoring
- White water solids concentration



Hygienic Sensors

Hygienic style sensors are designed for installation directly into food product lines where CIP cleaning is used.

One piece polypropylene construction with a surface finish of better than $Ra=0.9\mu m$ eliminates bacteria traps. 3A Certified.

Industry standard 3" Triclover connections.

Applications:

- Product breakthrough on plate heat exchangers
- Solids content in whey

Series 40 Sensors

'QuadBeam' optical systems use 2 pairs of infrared light emitting diodes and photodetectors which are pulsed in sequence.

Ratiometric signal processing compensates for changes in the optical properties of the emitters and detectors due to ageing and surface coating.

Effects of colour, temperature and changes in background ambient light are virtually eliminated.

Designed for use with the Quadbeam MSSD53 microprocessor based transmitters providing both relay and/or analogue outputs.

Physical dimensions and electrical characteristics are compatible with sensors from other suppliers allowing direct replacement.

SPECIFICATIONS*

Measuring Range

Immersion Sensor
0 to 2.5g/l in normal activated sludge

Hygienic Sensor
0 to 40% milkfat

(The measuring range will vary according to media and particle characteristics)

Accuracy:
+/-2% of reading

Repeatability:
+/-1% of reading

Temperature:
0 to 85 °C operating range

Pressure:
10 BarG

Cable:
Polyurethane covered cable rated to 95 °C. Extension cables can be supplied to extend the cable length up to a maximum of 100M.

MODEL NO. SELECTION GUIDE

Body Style:
S40-IMM - Immersion style body
S10-3HY - Hygienic style body with 3" Triclover fitting

Wavelength:
880 nm - Standard. Other wavelengths available.

Body Material:
PP - Polypropylene

Cable:
10 - Immersion sensors are supplied with a 10m cable as standard. Other lengths available.
1 - Hygienic sensors are supplied with a 1m cable as standard. Other lengths available.

Connector:
NC - No Connector. Cores stripped and crimped for direct connection to MSSD33/53 transmitters.

CA - Amphenol Connector. For use with Hygienic sensors using extension cables.

CS - Schaltbau Connector. For use with BTG/Zellweger Analytics transmitters.

Sample model no: S10-3HY-880-PP -1- CA

Optional Extras:
Cleaner - P owered using air at 10 Bar
Flanges/Adapters - To mount Immersion sensors into pipes or vessels, 50mm flanges or adapters for Triclamp, RJT and DIN11851 fittings are available.

Immersion Sensor

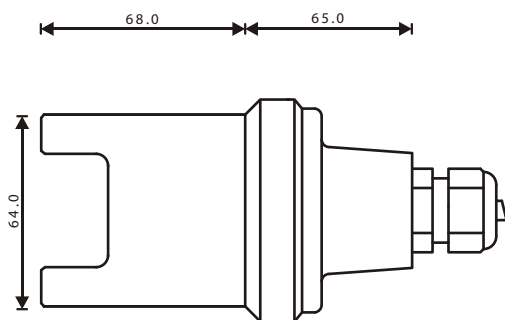

Hygienic Sensor

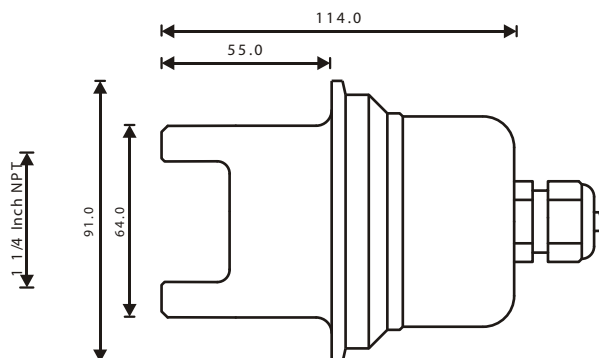

* Due to our policy of continuous improvements, specifications are subject to change without notice.